

CSENT

SENT/SAE J2716 Controller



The CSENT core implements a controller for the Single Edge Nibble Transmission (SENT) protocol. It complies with the SAE J2716 standard and is capable of driving pulses to trigger synchronous Sensor type. It can be used for conveying data from one or multiple sensors to a centralized controller using a single SENT line.

The CSENT core can be configured as a Transmitter and/or as a Receiver, and therefore it is suitable for adding an interface to devices transmitting sensor data or controllers receiving sensor data. It provides access to its control, status, and data registers 32-bit APB bus interface, comprehensive set of interrupt signals facilitates

interrupt-based operation. The core allows for Transmitter operation without requiring any external programming or control. The reset values for all its control registers are defined at synthesis time, and at run time the system only needs to write sensor data to the core.

The CSENT core is designed with industry best practices. The core contains no latches or tri-states, and is fully synchronous with a single clock domain. The core is available in Verilog or as targeted FPGA netlist. Deliverables provide everything required for a successful implementation, including sample scripts, an extensive testbench, and comprehensive documentation.

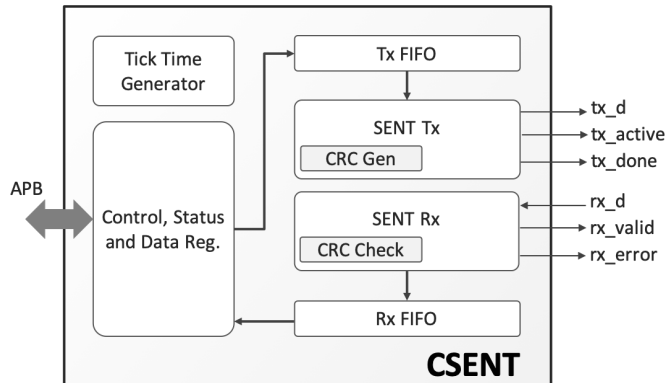

Applications

The CSENT core is suitable for designing low-cost digital automotive sensors and automotive controller units.

Size and Performance

The following are sample Altera implementation results, which do not represent the highest and do not include the area for the implementation of the FIFOs.

Configuration	Target Technology	Area	Fmax
TX & RX no FIFO	StratixV / 5sgxea9n3fc5c4	570 ALMs, 693 Regs	315 MHz
TX only no FIFO	StratixV / 5sgxea9n3fc5c4	275 ALMs, 351 Regs	339 MHz
TX & RX no FIFO	CycloneV / 5ceba9f31c7	571 ALMs, 697 Regs	162 MHz
TX only no FIFO	CycloneV / 5ceba9f31c7	279 ALMs, 351 Regs	185 MHz
TX & RX no FIFO	ArriaV / 5agxbb3d4f35c4	570 ALMs, 701 Regs	204 MHz
TX only no FIFO	Arria10 / 10as057k2f35i2lg	280 ALMs, 352 Regs	247 MHz
TX & RX no FIFO	US Kintex / xcku035-3	593 ALMs, 688 Regs	365 MHz
TX only no FIFO	Arria10 / 10as057k2f35i2lg	284 ALMs, 349 Regs	401 MHz

FEATURES

SENT/SAE J2716 Receiver & Transmitter

- Fast and Slow Channel Transmit or Receive
- CRC generation for Transmitter, and CRC checking for Receiver
- All types of SENT Frames
 - Programmable data length (4 to 24 bits) for Fast Channel Frames
 - Short (8-bit data) and Enhanced (12- or 16-bit data) Message Formats for Slow Channel
- Optional Pause Pulse with programmable length
- Supports inverted SENT protocol

Trigger Pulse for Synchronous Sensors

- Allows up to four sensors (transmitters) to use the same physical SENT connection
- Programmable master trigger pulse length

Ease of Integration

- 32-bit APB interface, and comprehensive set of interrupts
- Programmable 4-bit clock divider and high precision 16-bit clock pre-scale
- Receive and Transmit FIFO of configurable size for Fast Channel data
- Run-time programmable configuration registers
- Synthesis-time defined reset values for all registers, enables data transmit without control from host processor
- LINT-clean, single-clock domain, scan-ready design

Deliverables

- Targeted netlist
- Testbench
- Sample synthesis and simulation scripts
- Documentation