

LIN-CTRL

LIN Bus Master/Slave Controller



The LIN-CTRL core is a communication controller that transmits and receives complete LIN frames to perform serial communication according to the LIN Protocol Specification. It can be configured at run-time to operate either as a master or as a slave and supports versions 1.3, 2.0, 2.1, and 2.2 of the LIN protocol. The message transfers can be controlled via a microcontroller interface and a LIN transceiver is needed for the connection to the LIN bus.

The LIN-CTRL core is a microcode-free design developed for reuse in ASIC and FPGA implementations. The scan-ready design is strictly synchronous with positive-edge clocking and no internal tri-states. The robustly verified core has been production-proven multiple times.

The LIN controller core is available in two versions: Standard, and Safety-Enhanced. The Safety-Enhanced version implements ECC for SRAMs protection and uses spatial redundancy for protecting the inner logic of the core. The Safety-Enhanced versions are certified as *ISO-26262 ASIL-D Ready*.

Applications

The LIN-CTRL core is used to interface sensors and actuators in a variety of applications such as automotive, industrial, and home appliances.

Block Diagram

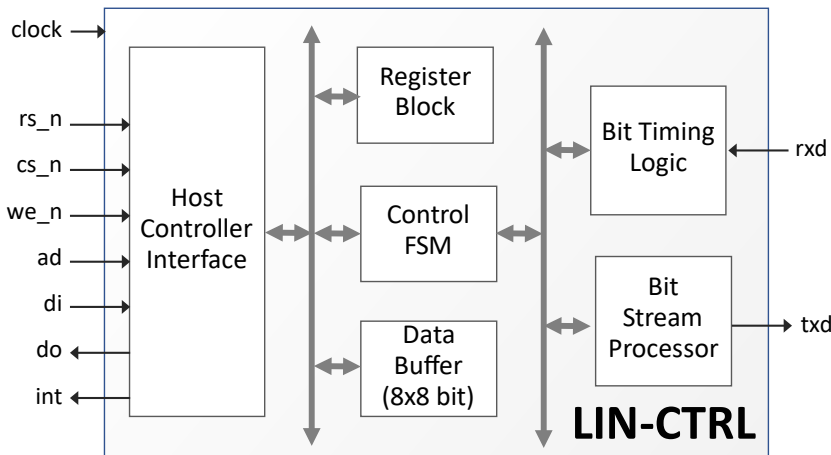

Functional Description

The LIN-CTRL core is partitioned into modules as shown in the block diagram.

Host Controller Interface

This interface is responsible for handling the communication with the host controller of the system.

Register Block

The Register Block provides control registers and status registers to control the LIN message transfer. Access to the registers is possible via the host controller interface.

Data Buffer

The 8-byte Data Buffer stores the data that has to be sent with the current LIN frame or the data that has been received with the last LIN frame. Access to the Data Buffer is possible via the host controller interface.

FEATURES

- Support of LIN specifications 2.0, 2.1, and 2.2A
- Backward compatible with LIN specification 1.3
- Run-time configurable master or slave operation
- Programmable data rate between 1 Kbit/s and 20 Kbit/s (for master)
- Automatic bit-rate detection (for slave)
- 8-byte data buffer
- Optional clock and input synchronization for slave operation
- Generic 8-bit microcontroller interface
- Wrappers converting the generic microcontroller interface to AMBA APB or AHB are offered with the core
- Fully synchronous design, available in Verilog, completely synthesizable
- The LIN Controller synthesizes to approximate 700 to 800 LUTs depending on the FPGA
- Robustly verified and multiple times production-proven IP core
- Safety -Enhanced Version (optional)
- Certified as ISO-26262 ASIL-D Ready
- Implements ECC for SRAM and spatial redundancy – DMR or TMR for inner logic protection, including optional lockstep operation

Functional Description (cont.)

Control FSM

The finite control state machine is responsible for the behavior of the core depending on host controller commands and bus activity. It generates and processes the LIN frame fields according to the LIN protocol.

Bit Stream Processor

This module converts the data stream from parallel to serial (from transmit buffer to bus) and from serial to parallel (from bus to receive buffer).

Bit Timing Logic

The Bit Timing Logic is responsible for synchronizing the received data stream from the bus with the internal bit time clock.

Implementation Results

The LIN-CTRL core can be mapped to any AMD FPGA device (provided sufficient silicon resources are available) and optimized to suit the particular project's requirements. The following are sample implementation data for the core assuming all I/Os are routed off-chip.

Family / Device	Logic Resources (LUTs)	Clock Freq ¹ (MHz)
Artix Ultrascale+ xc7s75-1-e	768	450
Kintex UltraScale xc7s75-1-c	781	350
Spartan 7 xc7s75-1	754	150

Notes:

1) Minimum clock frequency for the LIN controller is 8 MHz

Core Modifications

The LIN-CTRL core can be modified to include an acceptance filter. With that, a simple LIN slave that transmits response frames for only one identifier could be realized without the assistance of a host controller.

Please contact CAST, Inc. directly for any required modifications.

Support

The core as delivered is warranted against defects for ninety days from purchase. Thirty days of phone and email technical support are included, starting with the first interaction. Additional maintenance and support options are available.

Verification

The core has been verified through extensive synthesis, place and route, and simulation runs. It has been embedded in several shipping customer products, and is proven in both ASIC and FPGA technologies.

Deliverables

The core is available in synthesizable RTL and FPGA netlist forms. It ships with everything required for successful implementation, including:

- Verilog RTL source code, or targeted FPGA netlist
- Testbenches for behavioral, and post-synthesis verification
- Simulation and Synthesis scripts
- Low-Level Hardware Abstraction Layer (HAL)
- Optional MISRA C non-OS, bare-metal driver with advanced software examples
- User Documentation and RUVM register (IPXACT XML) descriptions.

The optional safety-enhanced package further includes the Safety Manual (SAM), a Failure Modes, Effects and Diagnostics Analysis (FMEDA) and the ASIL-D Ready certificate, issued by SGS-TÜV Saar GmbH.